

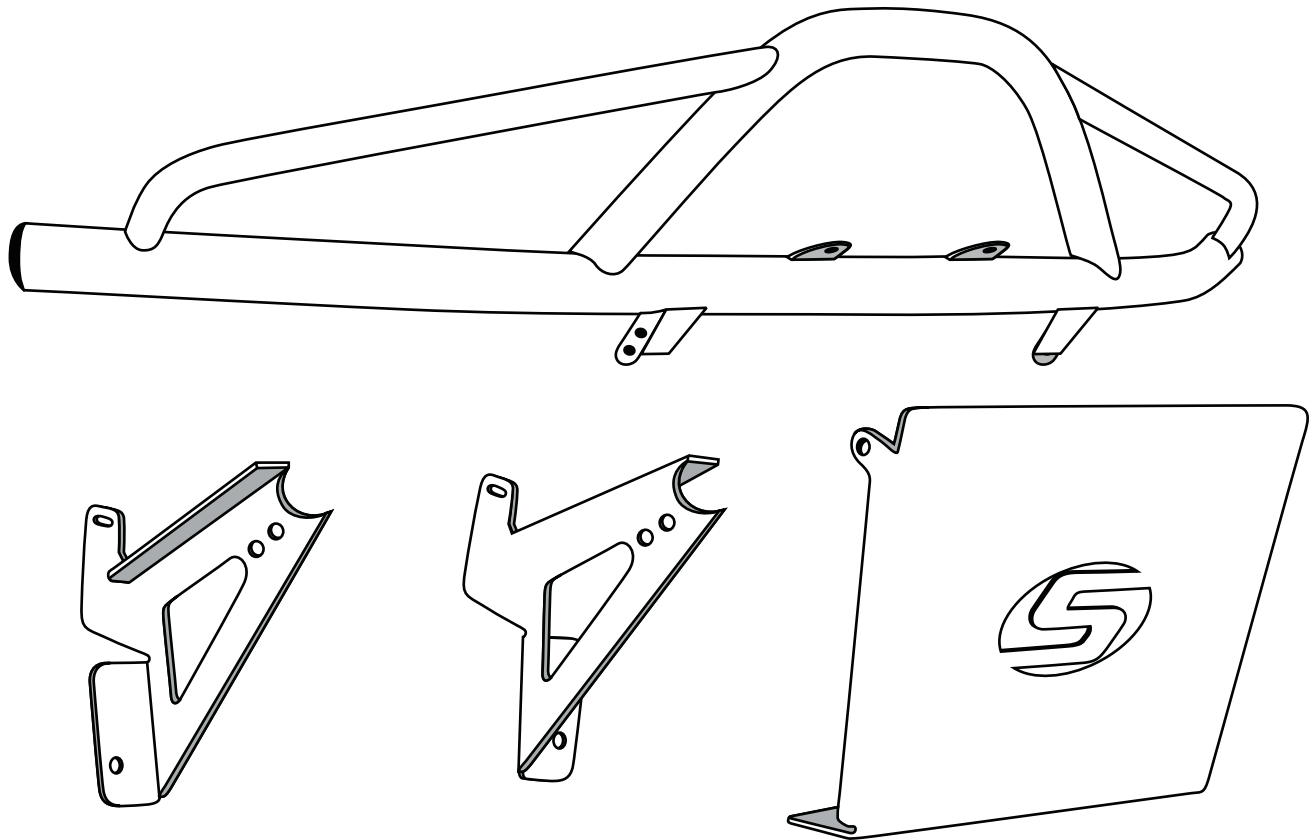

Yamaha RHINO

Front Bumper Installation

Part # 45300



Hardware Included

- 2 - 3/8" x 1" bolts
- 2 - 3/8" x 2 1/2" bolts
- 4 - 3/8" washers
- 4 - 3/8" nylock nuts
- 2 - 1" spacers

Tools Required

- 9/16" combination wrench
- 9/16" ratchet
- 14mm socket
- 17mm socket

Note: Leave all bolts loose until installation is complete. Once complete, tighten all bolts.

