

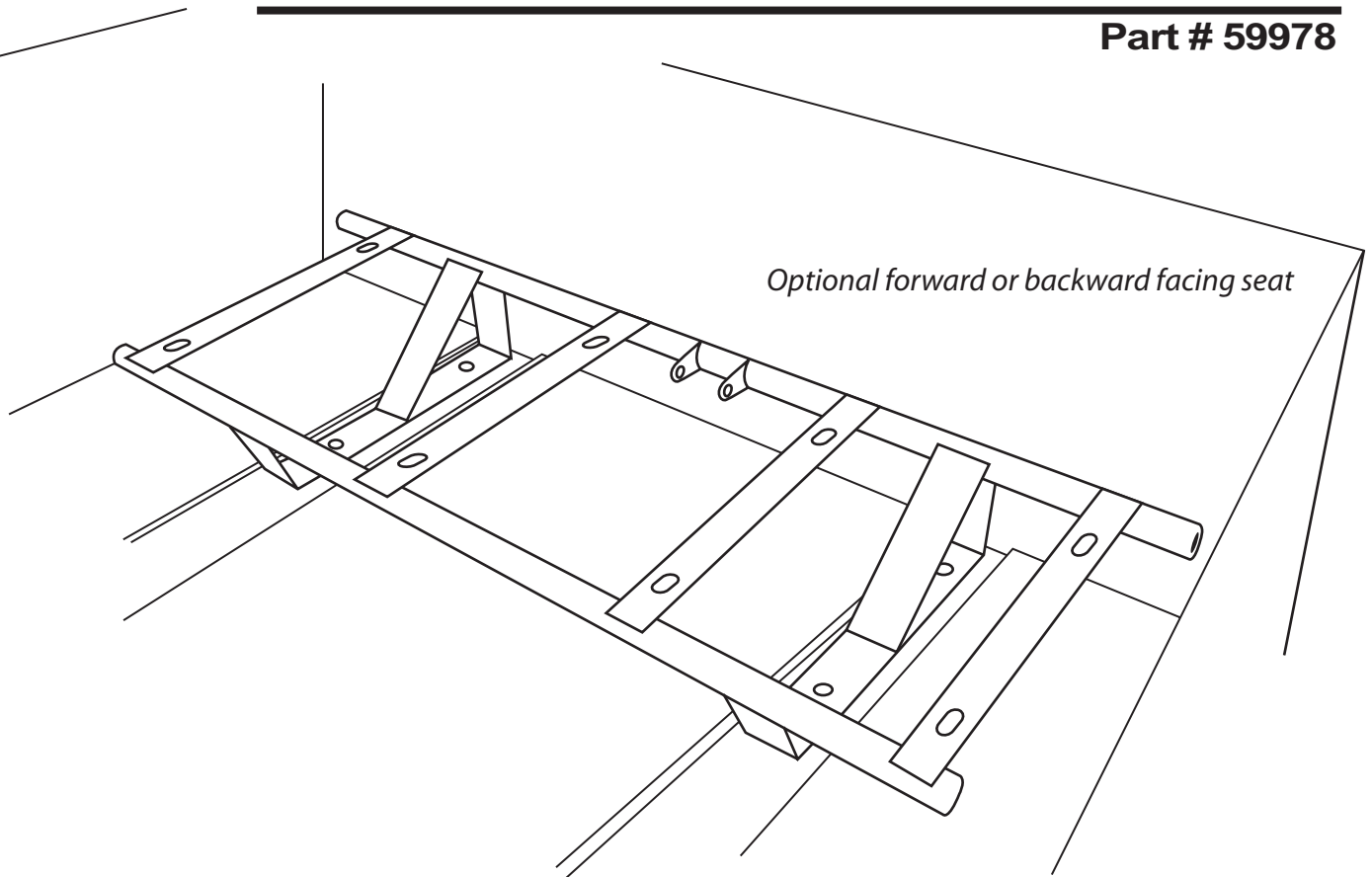

ArcticCat PROWLER

OEM Bench Seat Installation

Part # 59978



Hardware Included

Bracket Hardware

- 2 - **3 1/2" x 3/8"** bolts
- 4 - **3/8"** flatwashers
- 2 - **3/8"** nylock nuts
- 2 - **1 1/2" x 5/16"** bolts
- 4 - **5/16"** flatwashers
- 2 - **5/16"** nylock nuts

Bench Seat Hardware

- 4 - **1 1/4" x 3/8"** bolts
- 4 - **3/8"** flatwashers
- 2 - **3/8"** nylock nuts

Tools Required

- **1/2"** deepwell socket
- **9/16"** deepwell socket
- **1/2"** end wrench
- **9/16"** end wrench
- **3/8"** drill bit (min. 3" long)
- drill motor
- ratchet

Beard Prowler Rear Seat Mount Installation

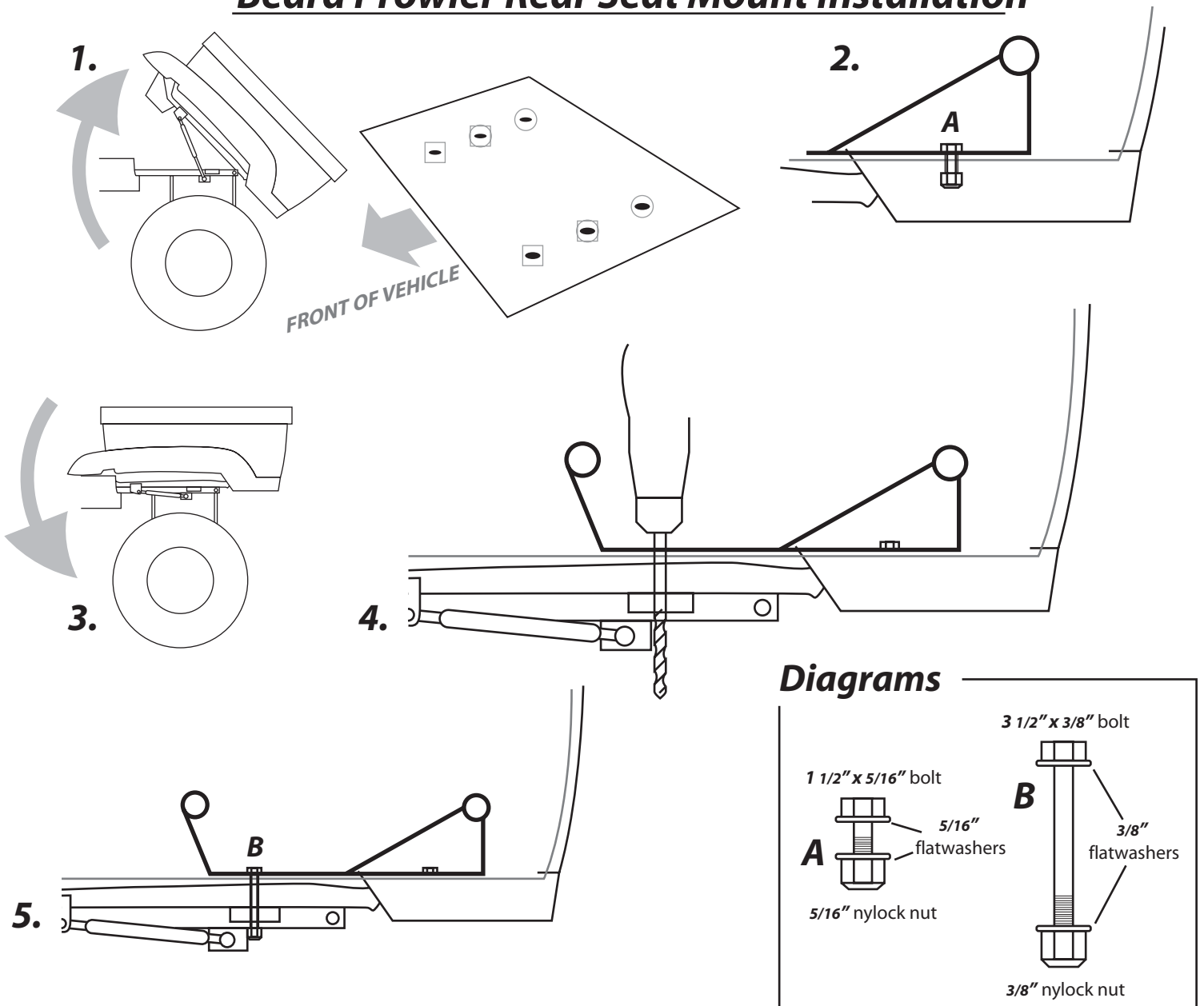

1. Tilt bed and remove four rear mounting bolts \square for forward facing seat and remove four forward mounting bolts \circ for rear facing seat from inside of bed.

2. Install bracket with two $1\ 1/2'' \times 5/16''$ bolts provided with bracket. Make sure that you include a $5/16''$ flatwasher under bolt head and under nut to frame, then lock with $5/16''$ nylock nut on bottom of bolt. (Diagram A)

3. Tilt bed back to normal position.

4. Drill, using $3/8''$ drill bit (min. 3" long), through two remaining bed mounting holes, through frame.

5. Install two $3\ 1/2'' \times 3/8''$ bolts provided with bracket. Make sure that you include a $3/8''$ flatwasher under bolt head and under nut to frame, then lock with $3/8''$ nylock nut on bottom of bolt. (Diagram B)

6. Install bench seat to bracket with provided four $1\ 1/4'' \times 3/8''$ bolts, $3/8''$ flatwashers, and $3/8''$ nylock nuts.



MUST BE USED IN CONJUNCTION WITH A REAR ROLL CAGE AND SAFETY HARNESS!